

# DSEPOWER® SHARING WITH SIMPLICITY.

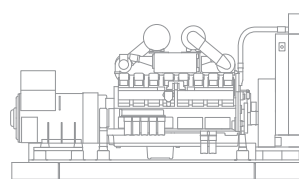

## DSE7520

AUTO MAINS (UTILITY) FAILURE & INSTRUMENTATION CONTROL MODULE



ELECTRONIC ENGINE CAPABILITY

The DSE7520 is an Automatic Mains (Utility) Failure Control Module designed to provide advanced load share functionality for diesel and gas generating sets that include non electronic and electronic engines, for single set applications and parallel with mains. The module also provides excellent monitoring and protection features.

The module monitors the mains (utility) supply and upon detection of a loss in power automatically starts the generating set.

The module's synchronising functions include automatic synchronising with built in synchroscope and closing onto dead bus. Direct and flexible outputs from the module are provided to allow connection to the most commonly used speed governors and automatic voltage regulators (AVRs).

The module has the ability to monitor generator under/over volts, over current, generator under/over frequency, under speed, over speed, charge fail, emergency stop, low oil pressure, high engine temperature, fail to start, low/high DC battery volts, fail to stop, generator short circuit protection, reverse power, generator phase rotation error, earth fault protection, loss of speed signal, fail to open, fail to close, out of sync, open circuit

failure, negative phase sequence and loss of excitation.

### FEATURES

- Electronic engine capability
- RS232 or RS485 remote communications
- Modbus RTU
- Pin number protected front panel programming
- Exercise timer
- Back-lit LCD 4-line text display
- Multiple language options
- Voltage measurement
- Configurable inputs (9)
- Configurable outputs (5)
- Automatic start
- Manual start
- Audible alarm
- LED indicators
- Built-in governor and AVR control for easy operation and panel engineering
- Engine history event log
- Engine protection
- Fault condition notification to a designated PC
- Front panel mounting
- PC configuration
- Mains (utility) failure detection
- Configurable alarm timers
- Configurable start & stop timers
- Automatic load transfer
- SMS alert messaging
- Multi set communications
- Front panel mounting
- Remote control and monitoring
- Dedicated load test button
- kW overload alarms
- Engine temperature alarms
- MV-LV synching

### LOAD SHARE FEATURES

- No-break transfer
- Peak shaving/peak lopping
- kW on mains (utility) level
- Mains (utility) decoupling test mode
- Manual speed/frequency adjust
- ROCOF & vector shift
- Dead bus sensing
- Direct governor & AVR communication
- Volts & frequency matching
- kW and kVar load sharing
- Manual voltage adjust

### BENEFITS

- Sends SMS messages to engineers to notify specific engine problems (GSM Modem and SIM card required)
- On-site and remote module configuration (Modem required)
- In-built engine diagnostics removes the requirement for service equipment
- Full engine protection & instrumentation without the need for additional senders (Electronic engines only)
- Remote monitoring of the module using comprehensive DSE PC software
- License free PC software
- No-break return capability

### SPECIFICATION

#### DC SUPPLY

8V to 35V continuous

#### CRANKING DROPOUTS

Able to survive 0V for 50mS, providing supply was at least 10V before dropout and supply recovers to 5V. This is achieved without the need for internal batteries

#### MAXIMUM OPERATING CURRENT

460mA at 12V. 245mA at 24V

#### MAXIMUM STANDBY CURRENT

375mA at 12V. 200mA at 24V

#### ALTERNATOR INPUT RANGE

15V(L-N) to 333V AC (L-N) absolute maximum

#### ALTERNATOR INPUT FREQUENCY

50Hz - 60Hz at rated engine speed (Minimum: 15V AC L-N)

#### MAGNETIC PICK-UP VOLTAGE RANGE

+/- 0.5V to 70V Peak  
1,000 Hz to 10,000 Hz

#### MAINS (UTILITY) SENSING RANGE

15V(L-N) to 333V AC (L-N) absolute maximum

#### MAINS (UTILITY) SENSING INPUT FREQUENCY

50Hz-60Hz (Minimum: 15V AC L-N)

#### START OUTPUT

15A DC at supply voltage

#### FUEL OUTPUT

15A DC at supply voltage

#### AUXILIARY OUTPUTS

Three outputs 2A DC at supply voltage  
Two outputs volt free 8A at 250V AC

#### GENERATOR LOADING RELAY OUTPUT

8A AC 250V AC

#### MAINS (UTILITY) LOADING RELAY OUTPUT

8A AC 250V AC

#### CHARGE FAIL/EXCITATION RANGE

0V to 35V  
Fixed power source 2.5W

#### BUILT-IN GOVERNOR AND AVR CONTROL

Fully Isolated  
Minimum Load Impedance:  
1000Ω  
Gain Volts: 0V-10V DC  
Offset Volts: + / - 10V DC

#### DIMENSIONS

240mm x 172mm x 57mm  
9.4" x 6.8" x 2.2"

#### PANEL CUTOUT

220mm x 160mm  
8.7" x 6.3"

#### DEGREES OF PROTECTION PROVIDED BY ENCLOSURES

BS EN 60529  
IP65 - Front of module when installed into the control panel with the supplied sealing gasket.

## ENVIRONMENTAL TESTING STANDARDS

### ELECTRO MAGNETIC COMPATIBILITY

BS EN 61000-6-2  
EMC Generic Immunity Standard for the Industrial Environment  
BS EN 61000-6-4  
EMC Generic Emission Standard for the Industrial Environment

### ELECTRICAL SAFETY

BS EN 60950  
Safety of Information Technology Equipment, including Electrical Business Equipment

### TEMPERATURE

BS EN 60068-2-1  
Ab/Ae Cold Test -30°C  
BS EN 60068-2-2  
Bb/Be Dry Heat +70°C

### VIBRATION

BS EN 60068-2-6  
Ten sweeps in each of three major axes  
5Hz to 8Hz @ +/-7.5mm, 8Hz to 500Hz @ 2gn

### HUMIDITY

BS EN 60068-2-30  
Db Damp Heat Cyclic 20/55°C @ 95% RH 48 Hours  
BS EN 60068-2-78  
Cab Damp Heat Static 40°C @ 93% RH 48 Hours

### SHOCK

BS EN 60068-2-27  
Three shocks in each of three major axes  
15gn in 11ms

## TIMERS & INPUT FUNCTIONS

The module has been designed to include the following timers and input functions:

- Start delay timer
- Stop delay timer
- Crank timer
- Crank rest timer
- Engage attempt & manual crank limit timers
- Safety on delay timer
- Warm up timer
- Cooling timer
- Energise to stop hold timer
- Pre-heat timer
- Pre-heat bypass timer
- Smoke limiting control timer
- Fail to stop timer
- Over speed over shoot timer
- Breaker pulse control timers
- DC battery alarm delay timers
- Sync/fail to sync timer
- Mains (utility) transient delay
- Transfer time
- Mains (utility) fail to open/close
- Parallel run time

## TYPICAL LOAD SHARE APPLICATION

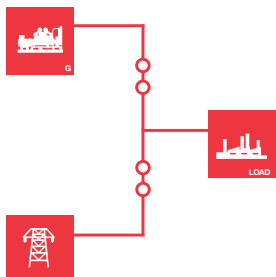

## OPERATION

The module is operated using the front STOP/RESET, MANUAL, AUTO and START pushbuttons. Three of these push buttons include an LED indicator. Additional pushbuttons provide LCD display scroll, lamp test, mute functionality and breaker control.

## BUILT-IN FUNCTIONS

- Alternator under/over volts
- Alternator under/over frequency
- Warning or shutdown on engine temperature, over/under speed, oil pressure
- Warning, shutdown or electrical trip on battery volts or over current
- Shutdown or electrical trip on reverse power, phase rotation or short circuit fault
- Earth fault shutdown
- Adjustable crank cycle/attempts
- Full remote control and telemetry
- 9 configurable digital inputs
- 5 configurable and 2 fixed relay/FET outputs
- System lock input
- Load switching control push-button inputs
- Restricted access to programming via PIN number
- Loss of excitation
- Negative phase sequence
- ROCOF/vector shift (mains (utility) decoupling)
- Peak lopping
- Peak shaving
- Mains (utility) reverse power

## INSTRUMENTATION AND ALARMS

The DSE7520 module provides advanced metering and alarm functionality via the LCD display. The information can be accessed using the display scroll pushbuttons. The table below shows the instrumentation and alarm features the module provides.

Engine Speed  
Engine Oil Pressure  
Coolant Temperature  
Battery Voltage  
Charge Alt Volts  
Engine Run Time  
Number of Starts  
Additional instrumentation as provided by the electronic ECU  
Next Maintenance (if enabled)  
Fuel Level  
Generator Volts (L-N)  
Generator Volts (L-L)  
Generator Hz  
Generator Amps  
Generator Earth Current  
Generator kW (L1,L2,L3)  
Generator Total kW  
Generator pf (L1,L2,L3)  
Generator Average pf  
Generator Total kVA  
Generator kWh  
Generator kVAh  
Generator kVAh  
Generator Phase Sequence  
Generator kVA  
Synchroscope  
Mains (utility) Volts (L- N)  
Mains (utility)Volts (L-L)  
Mains (utility)Hz  
Mains (utility)Amps  
Mains (utility)kW  
Mains (utility)kVA  
Mains (utility)pf  
Mains (utility)kVA  
Mains (utility)Phase Sequence

## TELEMETRY

The module gives the user full telemetry facilities when using the optional communications software. The module can be connected to a PC using the DSE810 PC interface or by using a suitable modem.

The PC software is Microsoft Windows™ based. All access into the module can be configured to become password protected to prevent unauthorised entry. The PC software allows the module to be controlled from a remote location.

## COMMUNICATIONS

The DSE7520 has a number of different communication capabilities:-

### SMS Messaging

When the module detects an alarm condition, it has the ability to send an SMS message to a dedicated mobile number, notifying an engineer of the problem. (GSM Modem and data enabled SIM Card required).

### Remote Communications

When the module detects an alarm condition, it dials out to a PC notifying the user of the exact alarm condition (modem required).

### Building Management

The module has been designed to integrate with new and existing building management systems.

### SCADA/PC Software

The module has the ability to be controlled, configured and monitored from a remote PC, using the DSE810 interface.

### EVENT LOG

The module includes a comprehensive event log that shows the 25 most recent alarm conditions and the date and time that they occurred. This function assists the user when fault finding and maintaining a generating set.

### EXPANSION MODULES

DSE157 Relay Output Expansion Module  
DSE545 & DSE548 Remote Annunciation Expansion Module  
DSE130 Input Expansion Module

### ELECTRONIC ENGINE COMPATIBILITY

- Cummins
- Deutz
- John Deere
- MTU
- Perkins
- Scania
- Volvo
- Isuzu
- Generic
- Plus additional manufacturers

# DSE7520

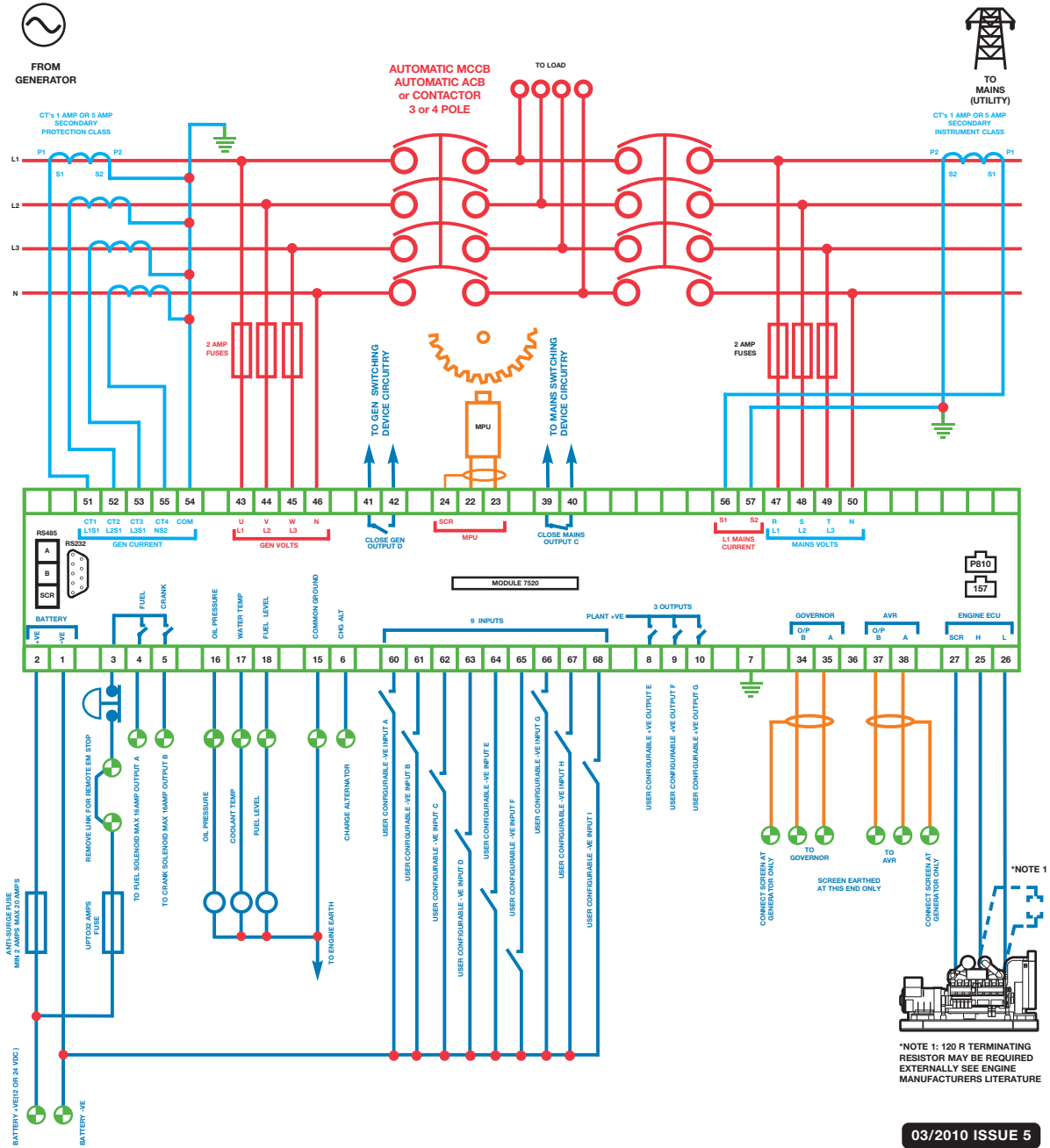

03/2010 ISSUE 5

## RELATED MATERIALS

TITLE	PART NO'S
DSE7520 Manual	057-089
DSE7520 Installation Instructions	053-053
DSE75xx PC Software Manual	057-078
DSE7510 Data Sheet	055-065
DSE7560 Data Sheet	055-067
Load Share Design and Commissioning	057-047
Guide to Synchronising and Load Sharing	057-045/6
CAN and DSE Wiring Guide	057-004
DSE850 Comms Software Data Sheet	055-072

**DEEP SEA ELECTRONICS PLC**

Highfield House  
Hunmanby Industrial Estate  
Hunmanby, North Yorkshire  
YO14 0PH England

**TELEPHONE**

+44 (0)1723 890099

**FACSIMILE**

+44 (0)1723 893303

**EMAIL**

sales@deepseapl.com

**WEBSITE**

www.deepseapl.com



Registered in England & Wales No.01319649

VAT No.316923457

**DEEP SEA ELECTRONICS INC**

3230 Williams Avenue  
Rockford  
IL 61101-2668 USA

**TELEPHONE**

+1 (815) 316 8706

**FACSIMILE**

+1 (815) 316 8708

**EMAIL**

sales@deepseausa.com

**WEBSITE**

www.deepseausa.com

**YOUR LOCAL DISTRIBUTOR.**

DEEP SEA ELECTRONICS PLC maintains a policy of continuous development and reserves the right to change the details shown on this data sheet without prior notice. The contents are intended for guidance only.

This data sheet is printed on 9lives 55 Silk, which is produced with 55% recycled fibre from both pre and post-consumer sources, together with 45% virgin ECF fibre.

